

# RF18HFENBSR

33" Wide, 17.5 cu. ft. Counter-Depth French Door Refrigerator

## Features

- 17.5 cu. ft. Capacity in Counter Depth Category
- 33" Wide
- LED Lighting
- Ice Maker in Freezer
- Twin Cooling System®
- Surround Air Flow
- Power Freeze and Power Cool Options
- Two Humidity-Controlled Crispers
- Tempered Glass Shelves
- Gallon Door Bins
- EZ-Open Handle™ on Freezer Door

## Convenience

- Cool Tight Door
- Door Alarm



French Door Design



Ice Maker in Freezer

## Available Colour:



Stainless Steel

## Signature Features

### COUNTER DEPTH

- More capacity, smaller floor space.
- Our 17.5 cu. ft. capacity French Door has enough room to fit up to 17 bags of groceries.<sup>1</sup>
- Stylish counter-depth design allows for more workable space in the kitchen.

<sup>1</sup> Grocery comparison based on each cubic foot of usable space equalling one paper bag.

### TWIN COOLING PLUS

- Refrigerator is kept at higher humidity levels to keep perishable fruits and vegetables fresher longer.\*
- Freezer air is kept drier for less freezer burn and better tasting frozen foods.
- Fruits and veggies are no longer limited to the crispers. Produce can be placed anywhere in the fresh food compartment and retain ultimate freshness.

\*When compared to Samsung fridge models that do not have Twin Cooling Plus.

### LED LIGHTING

- Beautifully lights up the interior so you're able to quickly spot what you want.
- Sleek design saves more space than traditional incandescent light bulbs.



Ranked **"Highest in customer satisfaction with French Door refrigerators, in a tie."**\*

—J.D. Power

**SAMSUNG**

# RF18HFENBSR

33" Wide, 17.5 cu. ft. Counter-Depth French Door Refrigerator

## Installing Your Refrigerator

1. Measure the height, width and depth of the opening, making sure to include baseboards, moulding tile, countertop overhang, etc. Check to be sure there is enough room to open the door (consider walls, islands or other obstacles when measuring).
2. Refer to illustration below to determine dimensions.
3. Allow 2" of clearance on hinge side of refrigerator when installing next to a wall where the handle may make contact.
4. Allow 1" minimum clearance at rear for proper air circulation and water/electrical connections. Allow a 3/8" minimum clearance at sides and top for ease of installation.
5. Ensure each door and entryway in the home is wide enough for the refrigerator to be moved through easily.

Please note: The following dimension and cut-out information is for planning purposes only. For complete installation details consult manual packed with product, or download manual online at [samsung.com](http://samsung.com).

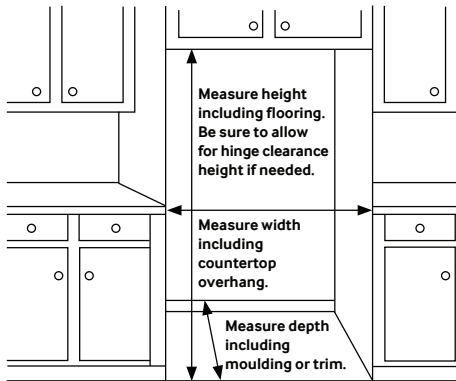

## Dimensions

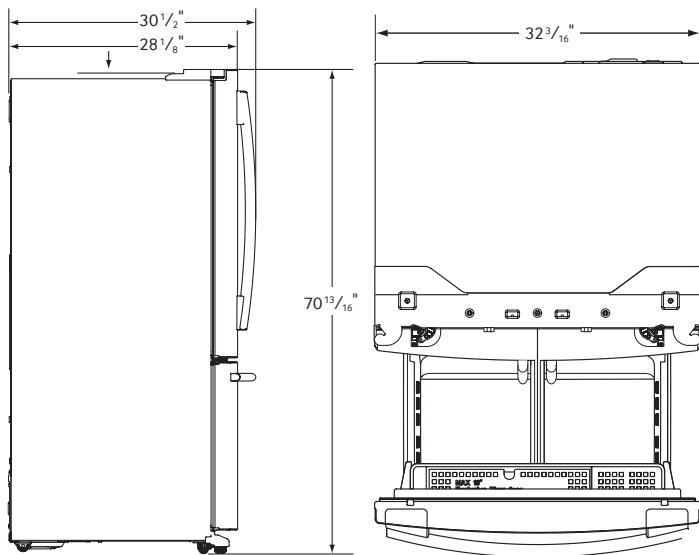

## Total Capacity: 17.5 cu. ft.

### Refrigerator: 11.79 cu. ft.

- Surround Air Flow
- 2 Humidity-Controlled Crispers
- 3 Tempered Glass Shelves
- 2 Gallon Door Bins
- 1 Dairy Bin
- LED Lighting

### Freezer: 5.72 cu. ft.

- EZ-Open Handle
- 1 Large Opaque Bin with Divider
- Automatic Filtered Ice Maker (Cubed)
- LED Lighting

## Accessories

External Filter: (not included)

## Warranty

One (1) Year Parts and Labour on Refrigerator

Five (5) Years Parts and Labour on Sealed Refrigeration System Only\*

Ten (10) Years Parts and Five (5) Years Labour on Digital Inverter Compressor

\*Compressor, evaporator, condenser, drier, connecting tubing.

## Product Dimensions & Weight

Dimensions (WxHxD with hinges, handles and doors):  
 $32\frac{3}{16}$ " x  $70\frac{13}{16}$ " x  $30\frac{1}{2}$ "

Dimensions (WxHxD without hinges and door):  
 $32\frac{3}{16}$ " x  $70\frac{13}{16}$ " x  $24\frac{5}{16}$ "

Dimensions (WxHxD with hinge and door, no handle):  
 $32\frac{3}{16}$ " x  $70\frac{13}{16}$ " x  $28\frac{1}{8}$ "

Weight: 231.5 lbs.

## Shipping Dimensions & Weight (WxHxD)

Dimensions:  $34\frac{11}{16}$ " x 75" x  $30\frac{1}{4}$ "

Weight: 253.5 lbs.

Colour	Model #	UPC Code
Stainless Steel	RF18HFENBSR	887276038414

**SAMSUNG**

Samsung received the highest numerical score for ranges/cooktops/ovens, microwaves, and french door refrigerators (3-way tie) in the proprietary J.D. Power and Associates 2014 Kitchen Appliance Study. The 2014 Kitchen Appliance Satisfaction Study is based on more than 3,200 evaluations from customers who purchased cooktops/ranges/ovens; more than 2,100 evaluations from customers who purchased over-the-range microwaves; and more than 6,400 evaluations from customers who purchased refrigerators during the past 24 months. The study was fielded from January through March 2014.

Actual colour may vary. Design, specifications, and colour availability are subject to change without notice. Non-metric weights and measurements are approximate.

© 2015 Samsung Electronics Canada Inc. All rights reserved. Samsung is a registered trademark of Samsung Electronics Co., Ltd., used with permission.

# DW80J3020US

## Samsung Dishwasher

### Features

- Quiet Operation – 50 dBA
- ENERGY STAR® rated: 265 kWh/Year
- Water Consumption: 3.5 Gallons
- 15 Place Settings
- Hidden Heating Element
- Double Filtration System
- Electronic Touch Sensor
- Hard Food Disposer
- 3 Spray Wash Arms (Upper, Middle, Lower)
- 4 Wash Cycles and 1 Wash Option
- Fan Condensing Drying System
- 2-Piece Silverware Basket
- 2" Adjustable Racking System
- Stainless Steel Interior

### Convenience

- Child Lock
- Rinse Refill Indicator
- Cycle Progress Indicator
- Last Cycle Memory
- Self-Cleaning Filtration System
- Five Sensors (Digital Water Leakage, Overflow, Sanitize, Turbidity, Water Fill)

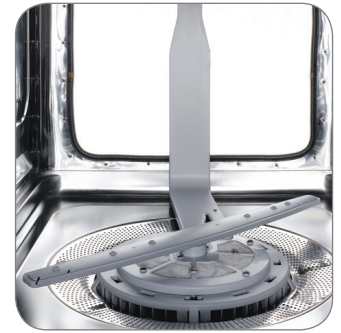

Hidden Heating Element



Hard Food Disposer

### Available Colors



Stainless Steel  
(shown)



White



Black

### Signature Features

#### STAINLESS STEEL INTERIOR

- Features a durable stainless steel tub that can help reduce energy consumption and aid in the drying process by retaining heat better than plastic tubs, allowing dishes to dry faster.

#### HARD FOOD DISPOSER

- Our advanced system allows for disposal of solid food particles with no need to clean a filter.
- Heavy foods are easily washed away without any pre rinsing or scrubbing involved.

#### HIDDEN HEATING ELEMENT

- Hidden Heat Element reduces the risk of melting plastic.

**SAMSUNG**

# DW80J3020US

Samsung Dishwasher

## Installing Your Dishwasher

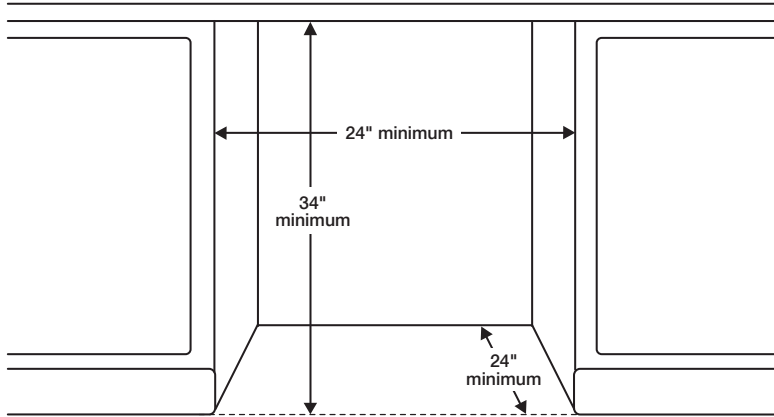

## Dimensions

Side View

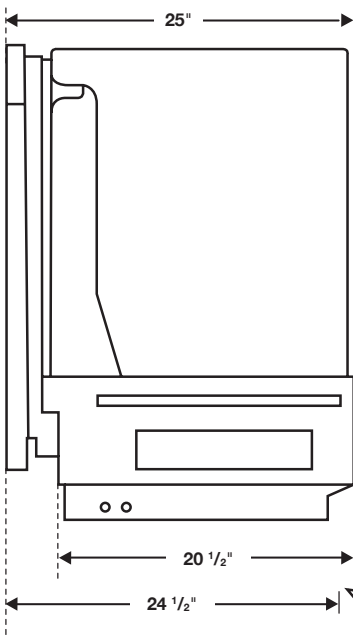

Rear View

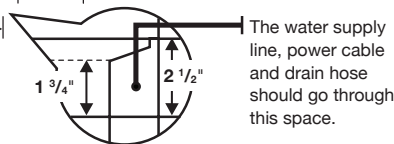
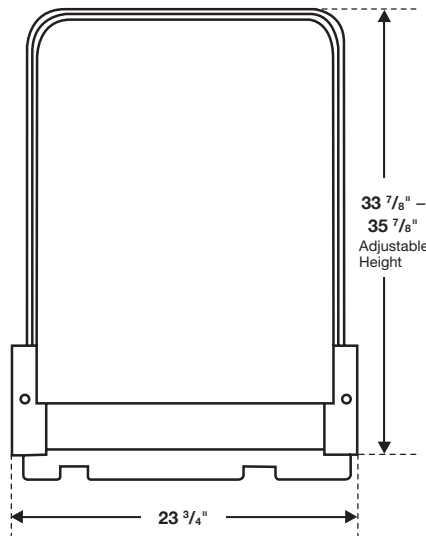

The water supply line, power cable and drain hose should go through this space.

## Features

- 4 Wash Cycles: Heavy, Normal, Quick Plus, Auto Wash
- 1 Option: Sanitize (Anti-Bacterial-NSF)
- 4 Control Buttons: Cancel and Drain (2 Buttons), Child Lock (1 Button), Start & Pause (1 Button)
- 2-Stage Filtration
- Hidden Heat Element
- Stainless Steel Interior Tub

## Convenience

- Child Lock
- Digital Water Leakage Sensor: Detects Water Leaks Before They Happen and Shuts Off the Dishwasher to Prevent Water Damage.
- Nylon Racking
- 2 Piece Silverware Basket
- Upper Rack: 2 Cup Shelves, 3 Adjustable Tines
- Upper Rack: 2 Fold Down Tine
- Lower Rack: 1 Removable Tine
- Cutlery Sleeves

## Warranty

One (1) Year All Parts and Labor

Five (5) Year Limited on Printed Circuit Board and Interior Nylon Racks

Lifetime Limited Warranty on Stainless Steel Door Liner and Tub for Leakage

## Product Dimensions & Weight (WxHxD)

Dimensions (height is adjustable):

23<sup>3</sup>/<sub>4</sub>" x 33<sup>7</sup>/<sub>8</sub>" – 35<sup>7</sup>/<sub>8</sub>" x 24<sup>1</sup>/<sub>2</sub>"

Weight: 91.1 lbs.

## Shipping Dimensions & Weight (WxHxD)

Dimensions: 27<sup>1</sup>/<sub>4</sub>" x 37<sup>3</sup>/<sub>4</sub>" x 28<sup>7</sup>/<sub>8</sub>"

Weight: 106.7 lbs.

Color	Model #	UPC Code
Stainless Steel	DW80J3020US	887276105529
White	DW80J3020UW	887276105543
Black	DW80J3020UB	887276105505

Actual color may vary. Design, specifications, and color availability are subject to change without notice.

Non-metric weights and measurements are approximate.

©2015 Samsung Electronics America, Inc. 85 Challenger Road, Ridgefield Park, NJ 07660. Tel: 800-SAMSUNG. samsung.com. Samsung is a registered trademark of Samsung Electronics Co. Ltd.

**SAMSUNG**

# NE58M9430SS

SAMSUNG

## Samsung Slide-In Electric Range

5.8 cu. ft. Capacity



### Signature Features

#### Dual Convection

- Faster and more even cooking.
- Two fans circulate air throughout the oven.

#### Slide-in design

- Blends seamlessly with your kitchen for a modern and built-in look.
- Creates a high-end look without having to remodel.

#### Flexible Cooktop

- Flexible 5 element cooktop with 2 double elements accommodates multiple pan sizes.
- 12"/9" and 9"/6" double elements allow for optimal placement and flexibility for various pots and pans.

### Available Colours



Stainless Steel



Dual Convection



Flexible Cooktop

### Features

- True Dual Convection
- Slide-In Design
- Flexible Cooktop – 5 Electric Elements
  - Two Dual Burners (9"/12", 6"/9")
  - Two Single Burners (6")
  - Warming Center (7")
- Glass-Touch Controls
- Large Oven Capacity: 5.8 cu. ft.
- Wide View Door
- Storage Drawer
- Hidden Bake Element
- Sabbath Mode

### Convenience

- Self + Steam Clean
- Hot Surface Indicator Lights
- Auto Oven Light
- Proofing
- Kitchen Timer
- Delay Start
- Auto Shut-Off Option
- Child Safety Lock
- 3 Preset Easy Cook Options

# NE58M9430SS

# SAMSUNG

## Samsung Slide-In Electric Range

5.8 cu. ft. Capacity

### Installation Specifications

30" minimum clearance between the top of the cooking surface and the bottom of an unprotected wood or metal cabinet; or 24" minimum when the bottom of the wood or metal cabinet is protected by not less than 1/4" flame-retardant millboard covered with not less than no.28 MSG sheet steel, 0.015" stainless steel, 0.024" aluminum or 0.020" copper.

\*\* 18" minimum between the countertop and the adjacent cabinet bottom.

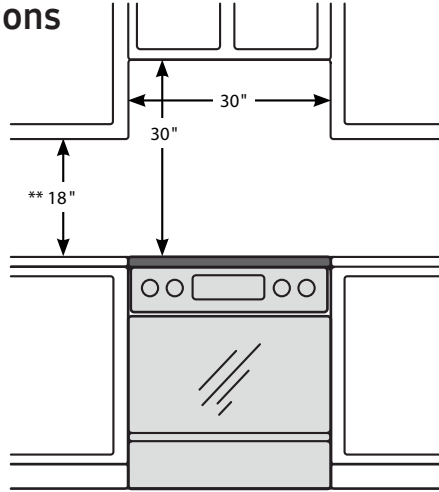

**IMPORTANT:** To eliminate the risk of burns or fire caused by reaching over heated surface units, cabinet storage space located above the surface units should be avoided. If cabinet storage is to be provided, the risk can be reduced by installing a range hood that projects horizontally a minimum of 5" beyond the bottom of the cabinets.

### Dimensions

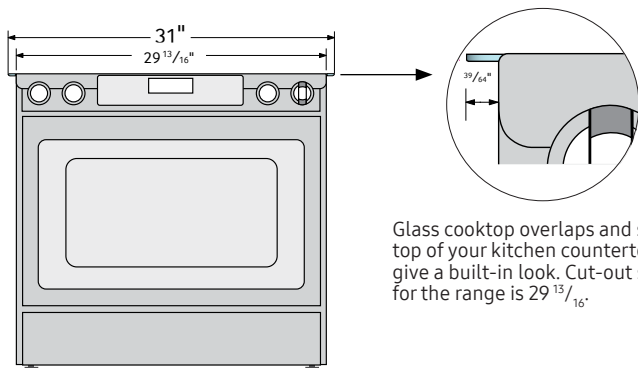

Glass cooktop overlaps and sits on top of your kitchen countertop to give a built-in look. Cut-out space for the range is 29<sup>13</sup>/<sub>16</sub>".

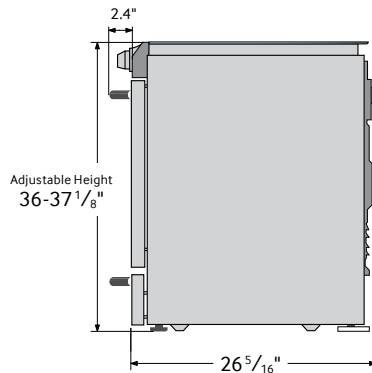

### Electric Ceramic Cooktop

- Right Front: 9/12", 3.0kW
- Left Front: 6/9", 3.0kW
- Right Rear: 6", 1.2kW
- Left Rear: 6", 1.2kW
- Warm Center: 100W

### Oven

- Hidden Bake Element: 3000W
- Bake: 175°F - 550°F
- Convection Bake: 175°F - 550°F
- Convection Roast: 175°F - 550°F
- Broil (Low - High)
- Convection Element/Heater: 1250W
- Proofing
- Sabbath Mode
- Storage Drawer Capacity - 0.7 cu. ft.

### Warranty

One (1) Year All Parts and Labour

### Product Dimensions & Weight (WxHxD)

Outside Net Dimensions:

31" x 36-37<sup>1</sup>/<sub>8</sub>" (Adjustable) x 26<sup>5</sup>/<sub>16</sub>"

Weight: 191.6 lbs.

### Shipping Dimensions & Weight (WxHxD)

Dimensions: 33<sup>1</sup>/<sub>16</sub>" x 41<sup>3</sup>/<sub>4</sub>" x 30<sup>5</sup>/<sub>16</sub>"

Weight: 215.8 lbs.

### Colour

Stainless Steel

### Model #

NE58M9430SS

**PERFEKT GLIDE 30**  
**30" Built-in Telescopic Range Hood**

**AEG**

# PERFEKT GLIDE 30

## 30" Built-in Telescopic Range Hood



### RANGE HOOD FEATURES

- 30" (76cm) stainless steel built-in glide-out range hood
- LED lighting
- 2 speed adjustment
- 2 x dishwasher safe honey comb filters
- Electronic push buttons
- Quiet (7 sones/56dB) 300 CFM motor

### RANGE HOOD DIMENSIONS

- D: 11" x W: 29<sup>15/16</sup>"
- D: 279mm x W: 760mm

### DUCT SIZE

- 6" Duct Adapter Included

### ELECTRICAL REQUIREMENTS

- 115 Volt, 60Hz, 15AMP
- AEG Range Hoods are supplied with a Canadian cord and plug
- Electrical cord located 6<sup>5/16</sup>" (160mm) from the top right corner of the unit at the rear



## Specifications

# PERFEKT GLIDE 30

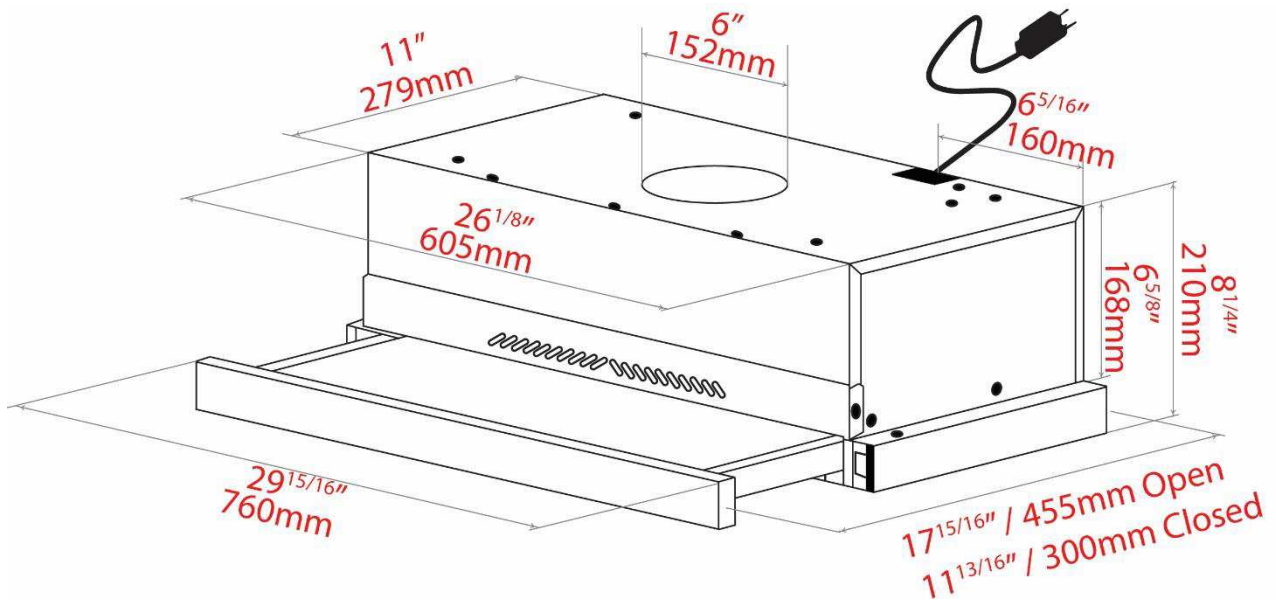

### FRONT PANEL - DUCTED

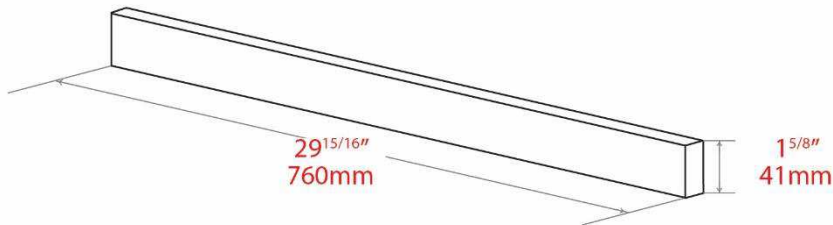

### RANGE HOOD DIMENSIONS

D: 11" x W: 29<sup>15/16</sup>"

D: 279mm x W: 760mm

# Specifications

## PERFEKT GLIDE 30

---

### CABINET BOX DESIGN

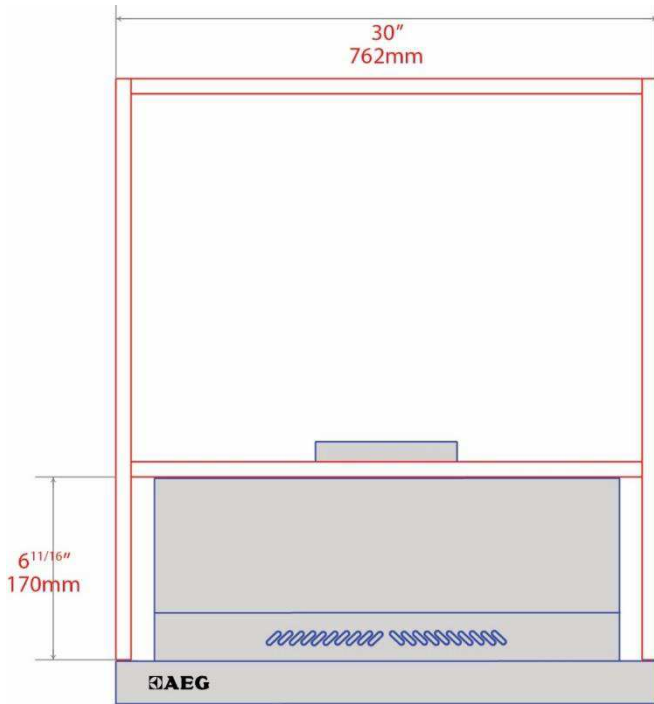

FRONT VIEW

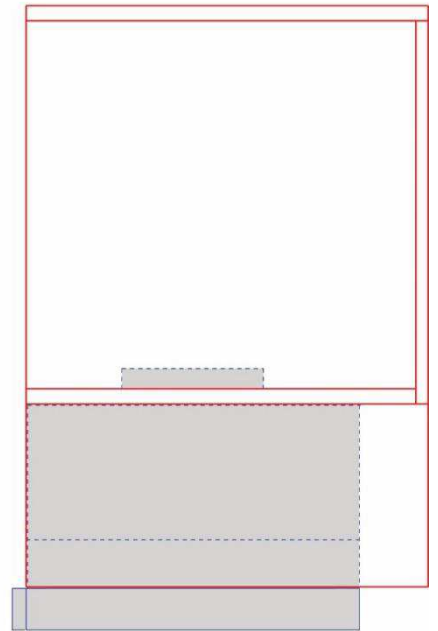

SIDE VIEW

## Specifications

# PERFEKT GLIDE 30

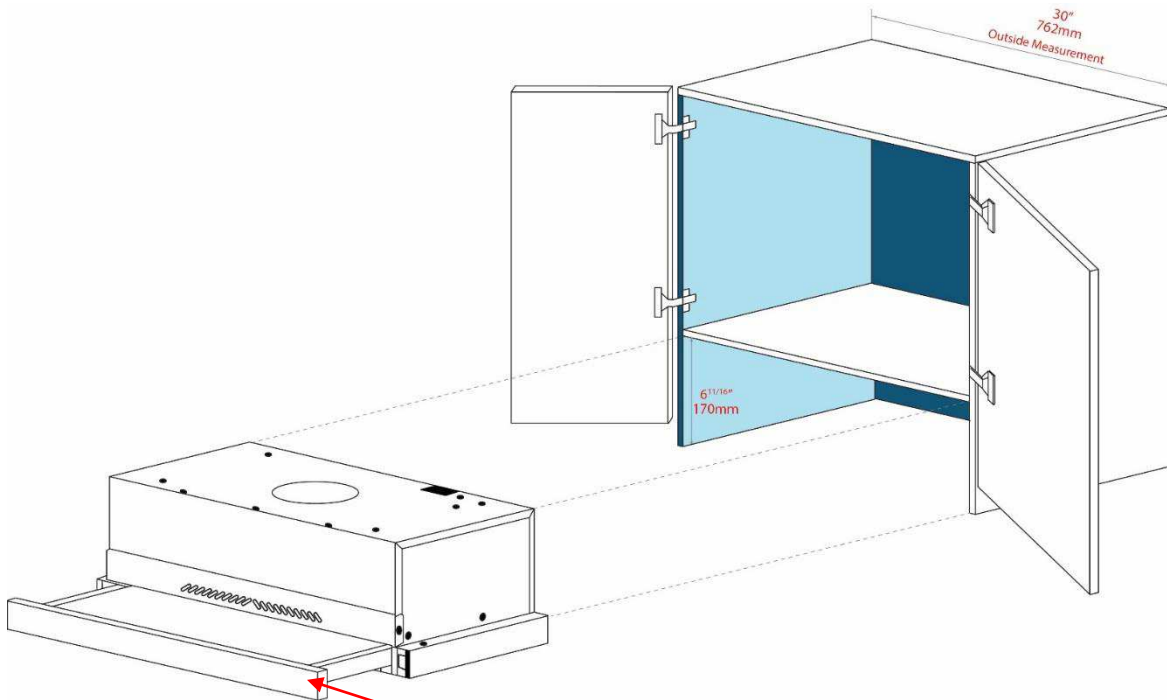

**NOTE: Removing the front stainless steel trim**

- 1. Pull the visor forward
- 2. Remove the 4 screws holding the visor to the panel
- 3. Install the matching front panel using the 4 screws

\*Custom panel provided by customer\*

# PERFEKT GLIDE 30

---

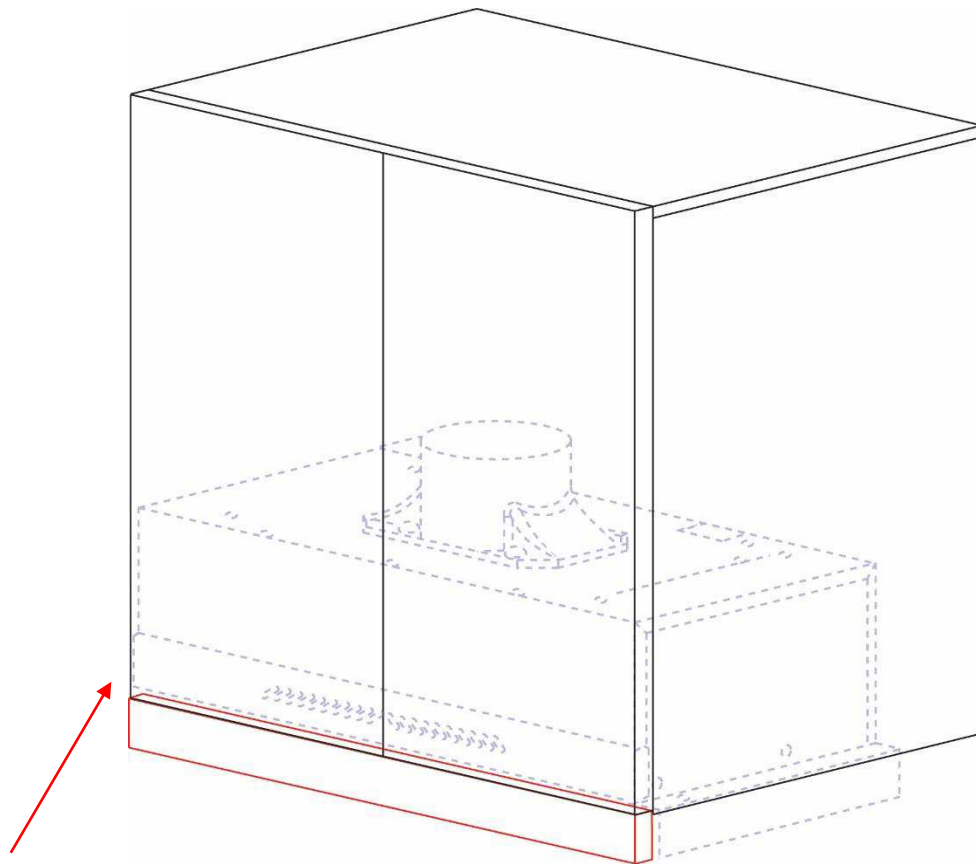

**NOTE: Cabinet Door Panel Height**

- Ensure that the cabinet door panel is lengthened to accommodate the smaller sized Range Hood Front Panel

Fit your family's lifestyle and living space with the 2.2 cu. ft. I.E.C. compact washer. This 24" washer installs virtually anywhere. Do laundry in almost any space with our space-saving compact washer. The compact front load washer offers exceptional fabric care—so you can enjoy all your favorite features on a small washing machine. Enjoy features like the Quick Wash cycle to clean small, lightly soiled loads or the Handwash cycle that cleans clothes gently in our compact washing machine.

## Whirlpool® 2.2 cu. ft. I.E.C. 24" Compact Washer with Detergent Dosing Aid option

WFW3090JW

### Available Finishes/Colours

WFW3090JW  
White

Dimensions		Controls	
Height	33 1/4	Motor Drive Type	Direct Drive
Width	24	Pedestal Options	Yes
Depth	24	Stackable	Yes
Depth With Door Open 90 Degree	41 5/8	Suspension System	2 Springs 3 Dampers
		Display Type	Digital, Cycle Indicator Lights

Configuration and Overview	
CEE Tier Rating	Not Rated
Energy Star® Qualified	ENERGY STAR® Qualified
UL	UL

Controls	
Sound Package	No
Out of Balance Sensing	Yes
Hoses Included	No
Basket Material	Stainless Steel

Cycle and Options	
Number of Spin Speeds	5
Temperature Combinations	Hot, Colors, Extra Hot, Cold, Cool, Warm
Number of Wash Cycles	10
Pre Soak	Yes

### Top Features

Detergent Dosing Aid

Sanitize option

Save Time option

### Manuals & Literature:

-  [Use and Care](#)  [Dimension Guide](#)
-  [Energy Guide](#)  [Installation Instructions](#)
-  [Warranty](#)



# Washer

## PRODUCT MODEL NUMBERS

### WFW3090G, WFW5090G

### Location Requirements

Proper installation is your responsibility.

#### You will need:

- A grounded electrical outlet located within 5.4 ft (1.7 m) of power cord on back of washer.
- Water faucet located within 4 ft (1.2 m) of water fill valve on washer, and water pressure of 20–100 psi (137.9–689.6 kPa).
- A level floor with maximum slope of 1" (25 mm) under entire washer. Installing on carpet or surfaces with foam backing is not recommended.
- Floor must support washer's total weight (with water and load) of 400 lbs (180 kgs).

**IMPORTANT:** Do not install, store, or operate washer where it will be exposed to weather or in temperatures below 32°F (0°C). Water remaining in washer after use may cause damage in low temperatures. See "Washer Maintenance" for winterizing information.

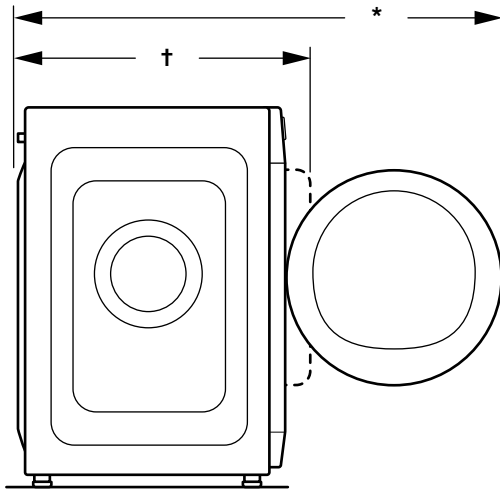
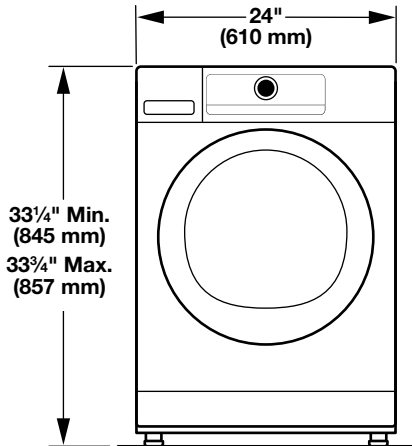

- \*2.3 cu. ft. models: 42<sup>5</sup>/<sub>16</sub>" (1091 mm)
- 1.9 cu. ft. models: 41<sup>5</sup>/<sub>8</sub>" (1057 mm)
- †2.3 cu. ft. models: 25<sup>1</sup>/<sub>8</sub>" (638 mm)
- 1.9 cu. ft. models: 24" (610 mm)

All dimensions show recommended spacing allowed, except for closet door ventilation openings which are the minimum required.

For each arrangement, consider allowing more space for ease of installation and servicing, and spacing for companion appliances and clearances for walls, doors, and floor moldings.

Space must be large enough to allow door to fully open. Add spacing of 1" (25 mm) on all sides of washer to reduce noise transfer. If a closet door or louvered door is installed, top and bottom air openings in door are required.

#### Recessed area or closet installation (stacked washer and dryer):

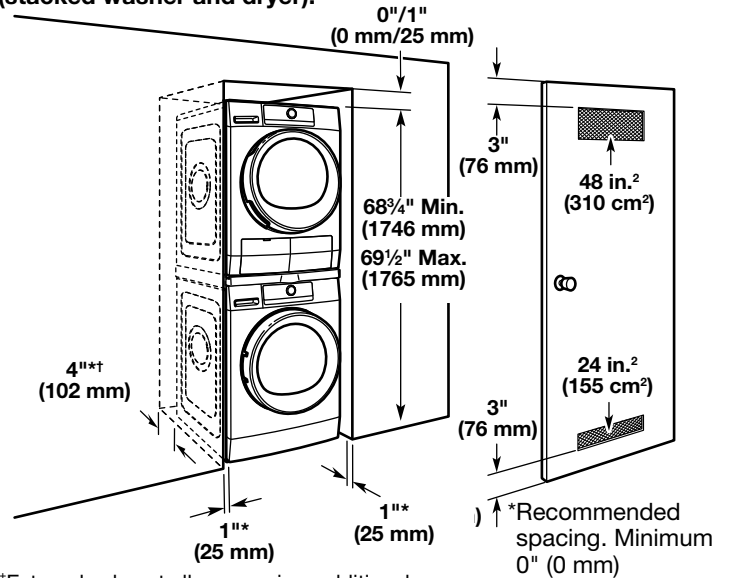

†External exhaust elbow requires additional space.

#### Custom under counter installation:

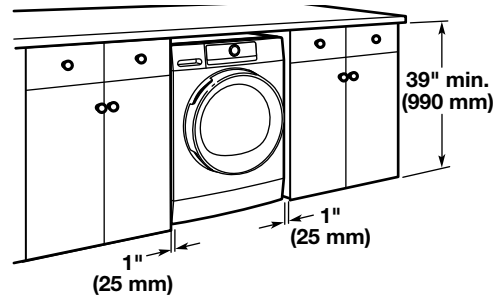

#### Custom cabinet installation:

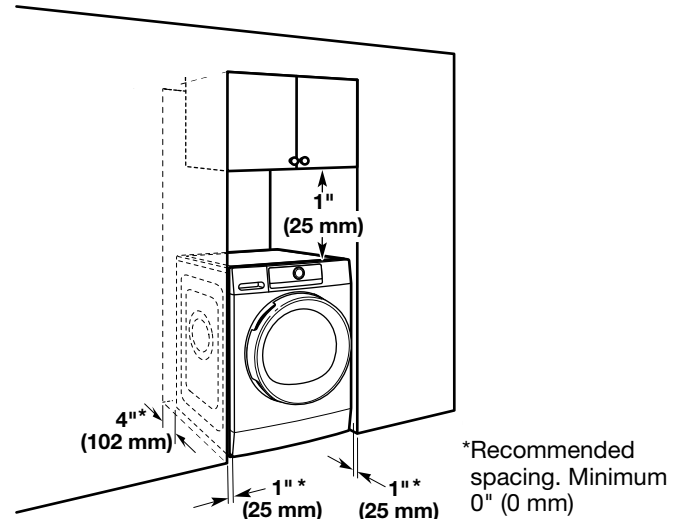

# ELECTRICAL REQUIREMENTS

A 120 volt, 60 Hz., AC only, 15- or 20-amp, fused electrical supply is required. A time-delay fuse or circuit breaker is recommended. It is recommended that a separate circuit breaker serving only this appliance be provided.

## Location Requirements (cont.)

### Closet installation (washer only):

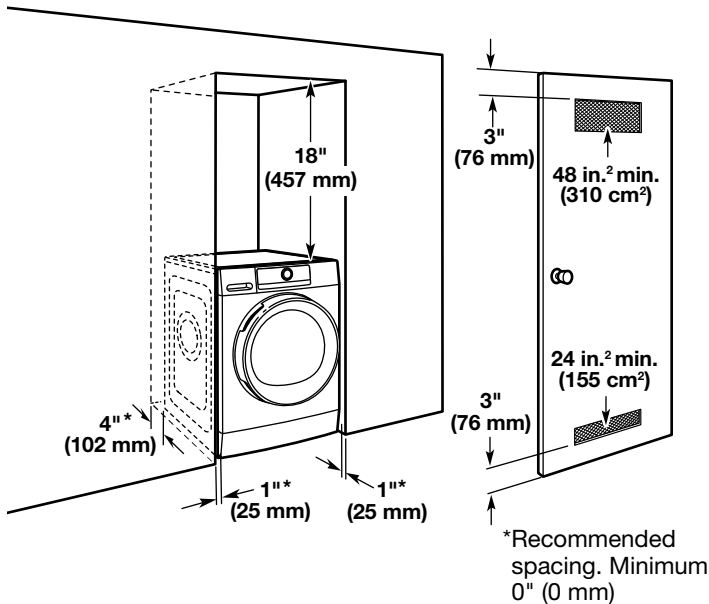

### Drain System

Drain system can be installed using a floor drain, wall standpipe, floor standpipe, or laundry tub. Select method you need.

**IMPORTANT:** To avoid siphoning, only 4½" (114 mm) of drain hose should be inside standpipe. Always secure drain hose with cable tie.

### Floor standpipe drain system

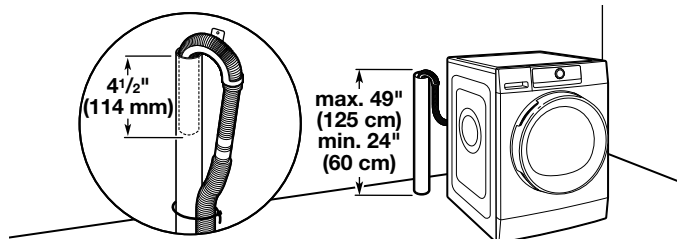

Minimum diameter for a standpipe drain: 2" (51 mm). Minimum carry-away capacity: 17 gal. (64 L) per minute. A 1¼" (6 mm) diameter to 1" (25 mm) diameter Standpipe Adapter Kit is available (Part Number 3363920). Top of standpipe must be at least 24" (60 cm) high; install no higher than 49" (125 cm) from bottom of washer. If you have an overhead sewer and need to pump higher than 96 inches, a sump pump and associated hardware are needed. See "Alternate Parts."

### Wall standpipe drain system

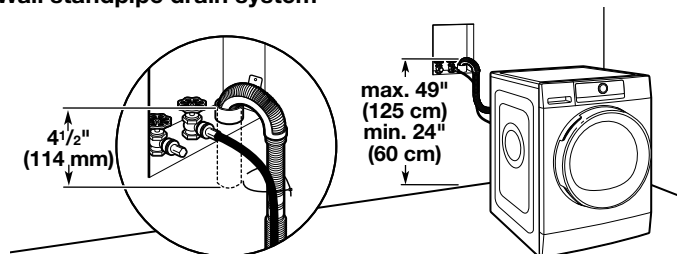

See requirements for floor standpipe drain system.

### Laundry tub drain system

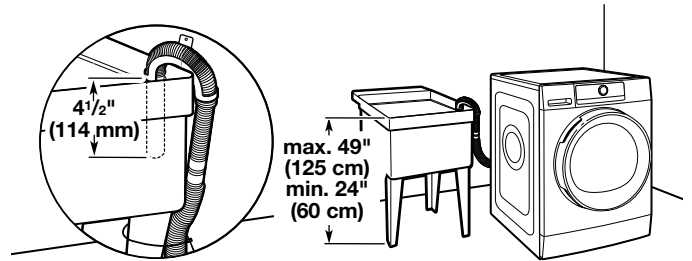

Minimum capacity: 20 gal. (76 L). Top of laundry tub must be at least 24" (60 cm) above floor; install no higher than 49" (125 cm) from bottom of washer.

### Floor drain system

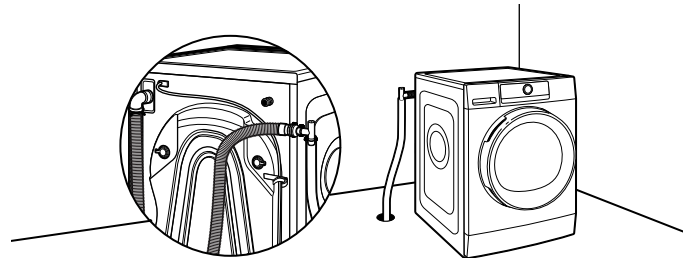

Floor drain system requires a Siphon Break Kit (Part Number 285834), 2 Connector Kits (Part Number 285835), and an Extension Drain Hose (Part Number 285863) that may be purchased separately. See "Alternate Parts." Minimum siphon break height: 28" (710 mm) from bottom of washer. (Additional hoses may be needed.)



# Whirlpool® 4.3 cu. ft. True Ventless Heat Pump Compact Dryer

YWHD3090GW

### Available Finishes/Colours

- YWHD3090GW White

### Dimensions

Width	24
Depth	25 3/4
Depth With Door Open 90 Degree	43 5/16
Minimum Height	33 5/8

### Configuration and Overview

Fuel Type	Electric
Capacity	4.30
Energy Star® Qualified	ENERGY STAR® Qualified

### Cycle and Options

Sound Package	No
---------------	----

### Style and Extras

Electronic Display Type	Digital
Automatic Temperature Controls	Yes
Drum Material	Stainless Steel
Drying Rack	No
Interior Light	No
Pedestal Options	No
Stackable	Yes
Steam Hose Y Connector	No
Feedback-Status Indicators	Bottom Filter Clogged, Delay Start, Door Filter Clogged, Water Tank Full

Fit your family's lifestyle and living space with the 4.3 cu. ft. compact dryer. This 24" dryer installs virtually anywhere and is our most space-saving dryer available. Tackle laundry day with this smaller washer and dryer with great features like X-Dry and the Refresh cycle. Enjoy a wrinkle-release dryer thanks to the Wrinkle Shield™ option. Better yet, this small dryer is also a very energy-efficient dryer.

### Cycle and Options

Number of Dryer Cycles	10
Advanced Moisture Sensor	Yes
Cycle Time Remaining	Yes
Lint Filter Indicator	No

### Top Features

**Our Most Space-Saving Design Available**

**Our Most Efficient Compact Dryer Technology**

**Wrinkle Shield™ Option**

### Manuals & Literature:

 [Use and Care](#)  [Installation Instructions](#)

 [Warranty](#)